

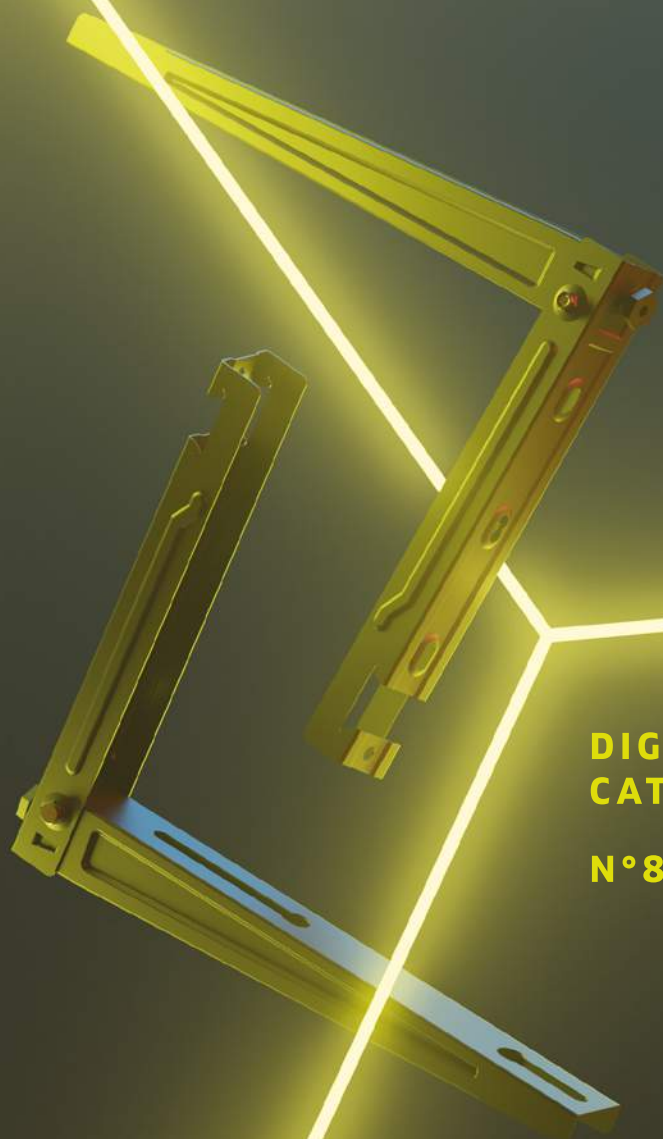

**ZEMMECLIMA**



**DIGITAL  
CATALOGUE**

**N°8**



**DIGITAL CATALOGUE N° 8**

# 01 — OUR STORY

100.000 staffe prodotte e vendute.

100.000 wall brackets produced and sold.

100.000 supports muraux produits et vendus.

100.000

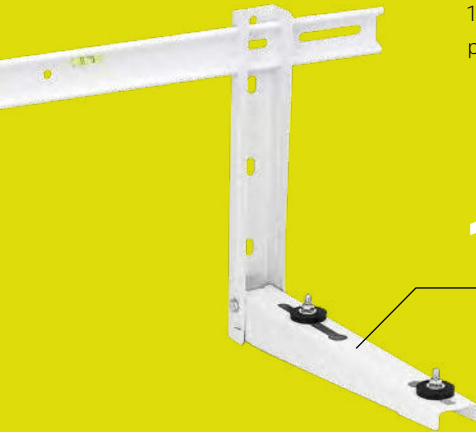

Seconda sede di 2.800 mq a Bastia di Rovolon, in provincia di Padova.

Second premise of 2.800 sq.m in Bastia di Rovolon, near Padova.

Deuxième usine de 2.800 m<sup>2</sup> à Bastia di Rovolon, proche de Padoue.

2017



2012

2008

Fondazione di 2 Emme Clima a Veggiano vicino a Padova.

2 Emme Clima foundation in Veggiano near Padova.

Fondation de 2 Emme Clima à Veggiano proche de Padoue.

2018

Creazione della gamma Titan per i supporti industriali e del marchio B.Revoc.

Creation of the Titan range for industrial units and of the B.Revoc brand.

Création de la gamme Titan pour les supports industriels et de la marque B.Revoc.



2013

Nuova sede di 2.000 mq a Bastia di Rovolon, in provincia di Padova.

New headquarter of 2.000 sq.m in Bastia di Rovolon, near Padova.

Nouveau siège de 2.000 m<sup>2</sup> à Bastia di Rovolon, proche de Padoue.



**TITAN**  
SUPPORT SYSTEMS

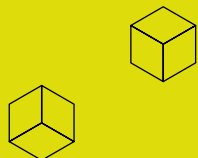

2021

**Integrazione dell'impianto di verniciatura: 2 Emme Clima diventa la prima azienda in Europa con un processo produttivo completo!**

Integration of the painting plant: 2 Emme Clima becomes the first company in Europe to have a complete production process!

Intégration de la cabine de peinture: 2 Emme Clima devient la première entreprise en Europe à avoir un processus de production complet!

**Fusione nel Gruppo Aspen Pumps.**

Merging in the Aspen Pumps Group.

Fusion à l'intérieur du groupe Aspen Pumps.



**1.000.000 di staffe prodotte e vendute.**

1.000.000 wall brackets produced and sold.

1.000.000 supports muraux produits et vendus.



2020



2022

**Una nuova sede con ulteriori 4500 mq completa la struttura organizzativa di 2 Emme Clima aggiungendo al reparto produttivo nuove linee automatizzate e presse.**

A new 4.500 sq.m premises complete the company structure adding to the production site new automated lines and presses.

Un nouveau siège de 4.500 m<sup>2</sup> vient compléter l'entreprise avec de nouvelles chaînes automatisées et presses.



2020

**Inserimento linea di assemblaggio automatizzata.**

Implementation of a new automated assembly line.

Insertion d'une chaîne d'assemblage automatisée.

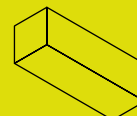
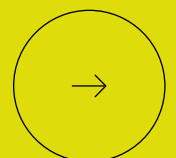

# 02 — CERTIFICAZIONI

## CERTIFICATIONS

Dalla nascita di 2 Emme Clima, qualità e affidabilità sono sempre state al centro del nostro business.

Per garantire tutto ciò ai nostri clienti, abbiamo deciso da sempre di affidarci all'ente TÜV SÜD per certificare le nostre staffe e i processi produttivi e per essere sempre in grado di soddisfare i più alti standard internazionali in termini di sicurezza, durata e sostenibilità.



2 EMME CLIMA

### 420 KG

**PORTATA TESTATA**  
TESTED LOAD CAPACITY  
PORTÉE TESTÉE

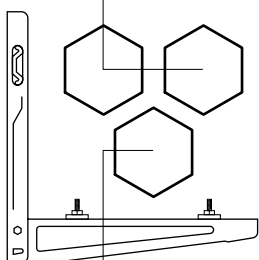

### 140 KG

**PORTATA CERTIFICATA**  
CERTIFIED LOAD CAPACITY  
PORTÉE CERTIFIÉE

[†] Testiamo i nostri prodotti con un carico tre volte superiore.

Our brackets are tested with a three times higher load capacity.

Produits testés avec un poids 3 fois supérieur.

### 500

**ORE**  
HOURS  
HEURES

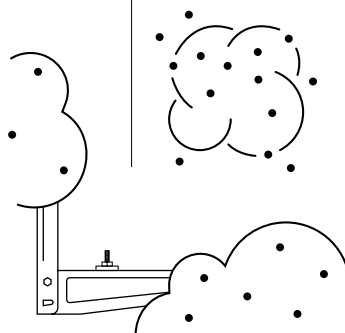

[←] Le nostre staffe vengono sottoposte ad un test di corrosione in nebbia salina di oltre 500 ore conforme a EN ISO 9227 per garantire un'alta resistenza nel tempo.

Our wall brackets are tested against corrosion with a neutral salt spray test over 500 hours according to EN ISO 9227 in order to ensure high resistance over the years.

Nos supports muraux sont testés contre la corrosion en brouillard salin durant plus de 500 heures conformément à l'EN ISO 9227 pour garantir une haute résistance au temps.



[←] Analizziamo la reazione delle staffe durante l'installazione tramite un test d'impatto.

We analyse the reaction of the brackets during the installation through an impact test.

Nous analysons la réaction des supports en phase d'installation grâce à un test d'impact.

Since the birth of 2 Emme Clima, quality and reliability have always been at the heart of our business.

To guarantee all this to our customers, we have always rely on the TÜV SÜD body to certify our brackets and production processes and to always be able to meet the highest international standards in terms of safety and sustainability.

Depuis la naissance de 2 Emme Clima, qualité et fiabilité sont au coeur de notre business.

Pour les garantir à nos clients, nous nous appuyons sur l'organisation TÜV SÜD afin de certifier nos supports et processus de production dans le but de satisfaire les plus hauts standards de qualité, durabilité et sécurité.

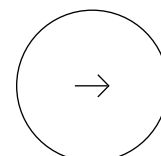

# 03 — GO GREEN

Il nostro impegno quotidiano nel miglioramento delle procedure e delle tecnologie utilizzate nel ciclo produttivo è volto a ridurre l'impatto sull'ambiente e sul territorio.

Our daily commitment to improve the processes and technologies used in the production cycle are aimed at reducing our impact on the environment and on the territory.

Notre engagement quotidien dans l'amélioration des procédés et des technologies utilisés dans notre cycle de production vise à réduire l'impact sur l'environnement et sur le territoire.



Siamo attenti alla salute dei nostri lavoratori garantendo un ambiente di lavoro sicuro e protetto.

Il nostro impianto di verniciatura è completamente automatizzato. Il recupero delle polveri è quasi totale (98%).

We take care of the health of our workers, guaranteeing a safe and secure working environment.

Our painting plant is completely automated. The 98% of the powder used is recovered in the production cycle.

Nous sommes attentifs à la santé de nos collaborateurs en garantissant un environnement de travail sûr et protégé. Notre cabine de peinture est complètement automatisée.

La récupération des poudres est presque totale (98%).



**Utilizziamo imballi completamente riciclati per i nostri prodotti.**

We use completely recycled packaging for our products.

Nous utilisons des emballages complètement recyclés pour nos produits.

Gli pneumatici sono progettati per durare nel tempo e i materiali di cui sono composti possono impattare sull'ambiente per più di un secolo. I nostri Brooklyn in gomma riciclata SBR aiutano a contrastare questo fenomeno riducendo l'inquinamento che ne deriverebbe.

Tires are designed to last over the years and their material can impact the environment for more than a century. Our Brooklyn in recycled rubber are helping to fight this phenomenon by reducing the pollution caused by tires.

Les pneus sont projetés afin de durer des années et les matériaux qui les composent peuvent avoir des conséquences sur l'environnement pendant plus d'un siècle. Nos Brooklyn en gomme recyclée SBR aident à lutter contre ce phénomène en réduisant la pollution qui en dériverait.

# 04 — REALTÀ AUMENTATA

AUGMENTED REALITY / RÉALITÉ AUGMENTÉE

Visualizza e interagisci con i prodotti 2 Emme Clima in un'esperienza multimediale unica in 3D da goderti su smartphone e tablet. Inquadrando l'immagine del prodotto che funge da marker potrai vederne in dettaglio ogni parte e le relative informazioni tecniche. Scarica l'app 2 Emme Clima per vivere questa nuova esperienza virtuale.

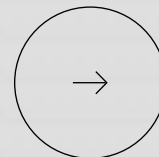

2 EMME CLIMA

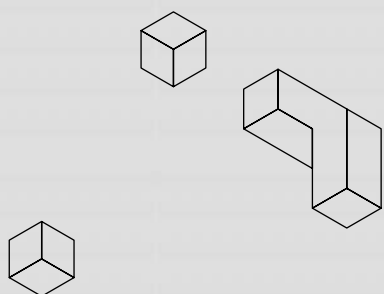

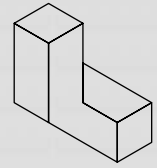

View and interact with 2 Emme Clima products in a unique 3D experience that you can enjoy on your smartphones and tablets. Framing the product image, you will be able to see all the details and related technical information. Download 2 Emme Clima APP to live this new virtual experience.

Visualise et interagis avec les produits 2 Emme Clima au cours d'une expérience unique en 3D sur smartphones et tablettes. En encadrant l'image qui agit comme marker, tu pourras voir chaque détail et toutes les informations techniques du produit. Télécharge l'application 2 Emme Clima pour vivre cette nouvelle expérience virtuelle.

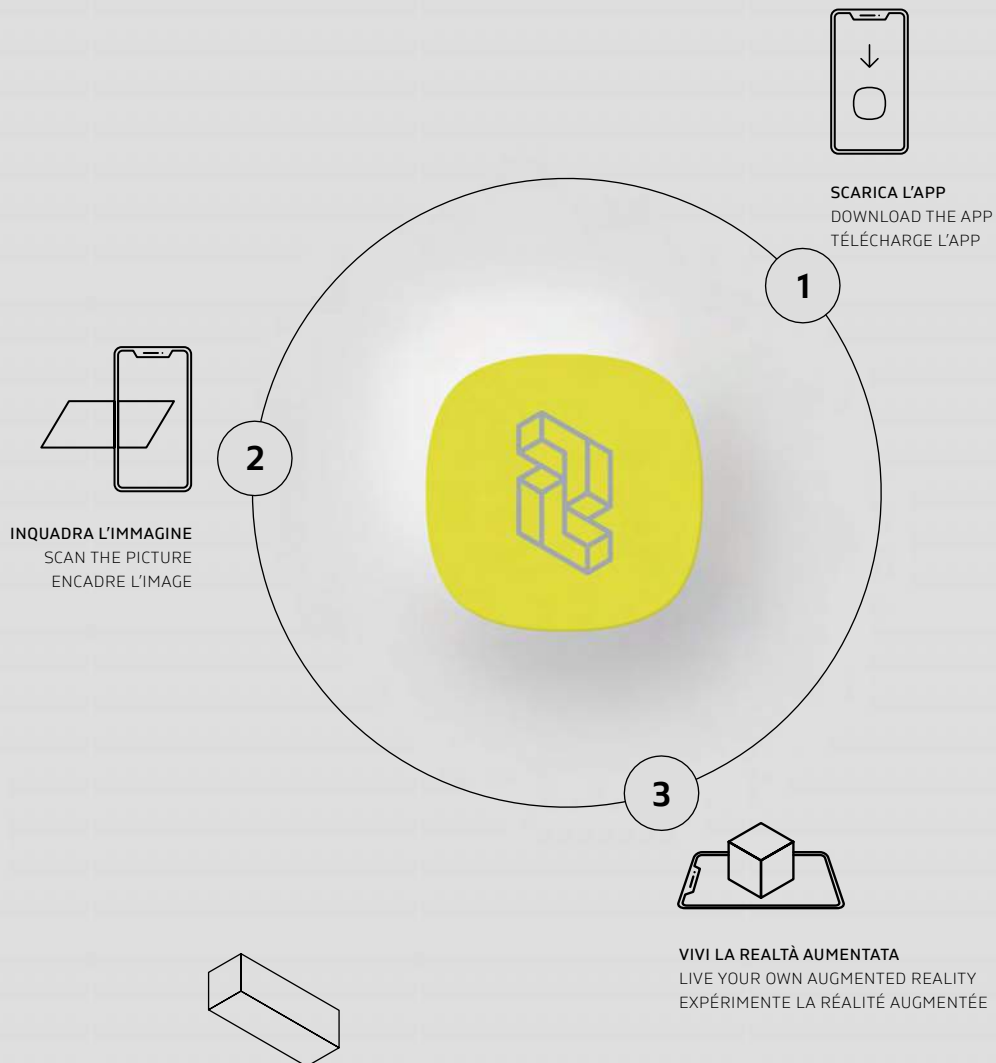

2 EMME CLIMA



INQUADRA IL QR CODE E SCARICA L'APP 2 EMME CLIMA AR  
FRAME THE QR CODE AND DOWNLOAD THE 2 EMME CLIMA AR APP  
ENCADRE LE QR CODE ET TÉLÉCHARGE L'APP 2 EMME CLIMA AR



# 05 — INDEX

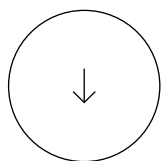

## INSTALLAZIONE A MURO

WALL INSTALLATION  
INSTALLATION MURALE

I.FLY	10
B.REVOC	11
CLOCK TYPE 2	12
TYPE 2	13
CLOCK TYPE 3	14
TYPE 3	15
TYPE 5	16 - 17
<b>HEAVY DUTY</b>	18
<b>HEAVY DUTY SPECIAL</b>	19
SUPER LIGHT	20
TYPE 1	21
SALDATE WELDED BRACKETS / SUPPORTS SOUDÉS	22
SPECIAL	23
BACINELLE TRAYS / BAC DE RECUPERATION	24
CAVI SCALDANTI HEATING CABLES / CÂBLES CHAUFFANTS	25
ANTIVIBRANTI RAINBOW RAINBOW ANTIVIBRATION DAMPERS KIT ANTI-VIBRATILES RAINBOW	26
ANTIVIBRANTI PER STAFFE ANTI-VIBRATION DAMPERS FOR WALL BRACKETS KIT ANTI-VIBRATILES SUPPORTS MURAUX	27

## DISTRIBUZIONE

DISTRIBUTION

48

**INQUADRA IL QR-CODE ALLA FINE DEL CATALOGO E ACCEDI ALLA GAMMA**

FRAME THE QR CODE AT THE END OF THE CATALOGUE TO DISCOVER THE RANGE

ENCADRE LE QR CODE À LA FIN DU CATALOGUE ET CONSULTE LA GAMME



## INSTALLAZIONE A PAVIMENTO

GROUND INSTALLATION  
INSTALLATION AU SOL

29

<b>KIT HEAT PUMPS</b>	30
<b>REGULAR</b>	31
<b>BROOKLYN BASE + RISER BLOCK</b>	32
<b>BROOKLYN BASE HIGH RISE</b>	33
<b>BROOKLYN EXTRA</b>	34
<b>BROOKLYN MINI</b>	35
<b>BROOKLYN SYSTEM</b>	35
<b>BASI A PAVIMENTO</b> GROUND SUPPORTS / SUPPORTS DE SOL	36
<b>METAL BOX</b>	37
<b>ANTIVIBRANTI A PAVIMENTO</b> GROUND ANTIVIBRATION DAMPERS KIT ANTI-VIBRATILES AU SOL	38



## INSTALLAZIONE A TETTO

ROOF INSTALLATION  
INSTALLATION SUR TOIT

39

<b>STAFFA A TETTO</b> ROOF BRACKETS / CHÂSSIS DE TOITURE	40
<b>STAFFE SOLARE A TETTO</b> SOLAR BRACKETS SUPPORTS DE FIXATION PANNEAUX SOLAIRES	41
<b>GIANT STANDARD FRAME + MULTI FRAME</b>	42
<b>BIG GIANT + MULTI FRAME</b>	43
<b>BRIDGE + HIGH LOAD</b>	44
<b>ACCESSORI DI RICAMBIO</b> SPARE PARTS / ACCESSOIRES	45 - 46
<b>TAPPETINI ANTIVIBRANTI</b> ANTIVIBRATION PADS / TAPIS ANTI-VIBRATILES	47



**POMPA DI CALORE**

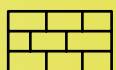

# INSTALLAZIONI A MURO

WALL INSTALLATION  
INSTALLATION AU MUR





# I.FLY



RAL  
9002



COLOUR

TESTED  
110 KG

**PRODOTTO BREVETTATO**

PATENTED PRODUCT

PRODUIT BREVETÉ

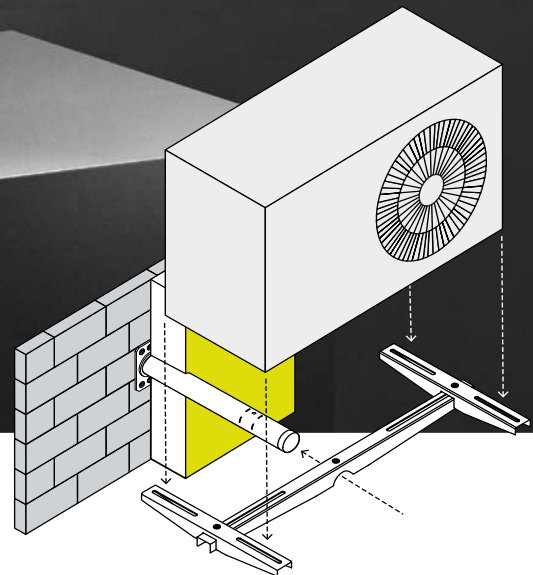

2 EMME CLIMA

**NEW**

## STAFFA PER CAPPOTTO TERMICO

WALL BRACKET FOR THERMAL INSULATION COATING

SUPPORT MURAL POUR ISOLATION THERMIQUE EXTÉRIURE

[IT]

### UNA NUOVA ERA DI SUPPORTI

Scopri I.FLY, la prima staffa al mondo installabile in fase di costruzione con cappotto termico.

[EN]

### A NEW ERA OF WALL BRACKETS

Discover I.FLY, the first wall brackets for the installation on thermal insulation coating.

[FR]

### UNE NOUVELLE ÈRE DE SUPPORTS MURAUX

Découvrez I.FLY, le premier support qui s'installe en phase de construction avec l'Isolation Thermique par l'Extérieur.



IFY-11



800 mm



465 mm



482 mm



382 mm



110 kg

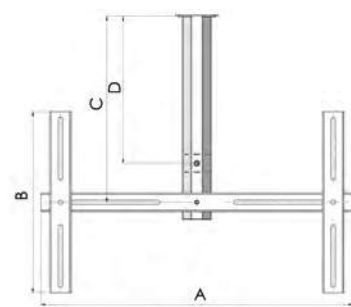



# B.REVOC



COLOUR



COLOUR



CERTIFIED  
120-160 KG

**PRODOTTO BREVETTATO**  
PATENTED PRODUCT  
PRODUIT BREVETÉ



2 EMME CLIMA



BEFORE



AFTER



Product video



Installation

[IT]

### PROTEGGI LE STAFFE, PROTEGGI I MURI DI CASA CON IL KIT B.REVOC.

La sola cover presente nel mercato per staffe di condizionamento ideata per migliorare l'aspetto dell'installazione con un design unico e innovativo.

**Kit B.Revoc per staffa Clock Type 2.**

[EN]

### PROTECT YOUR BRACKETS, PROTECT YOUR WALLS WITH B.REVOC.

The only cover for wall brackets present in the market with an unique and innovative design to improve the aesthetic of the installation.

**Kit B.Revoc for Clock Type 2.**

[FR]

### PROTÉGEZ VOS SUPPORTS MURAUX ET VOS MURS GRÂCE AU KIT B.REVOC.

L'unique coque de protection disponible sur le marché créée dans le but d'améliorer l'aspect esthétique de vos installations.

**Kit B.Revoc pour Clock Type 2.**

<b>BRS-210</b>	P420xH400xL800 mm	50 set	120 kg
<b>BRS-211</b>	P465xH400xL800 mm	50 set	160 kg
<b>BRS-213</b>	P550xH400xL800 mm	50 set	160 kg

Disponibile versione solo Cover  
Cover available without brackets  
Coque disponible sans support



# CLOCK TYPE 2



COLOUR

COLOUR

CERTIFIED  
120-160 KG



2 EMME CLIMA

PLUS - M8 8.8



RAL 9005

[IT]

**STAFFE UNIVERSALI REGOLABILI  
PREMONTATE E NON CON AGGANCIO  
RAPIDO.**

[EN]

**ADJUSTABLE UNIVERSAL PRE-  
ASSEMBLED AND NON WALL  
BRACKETS WITH HOOK SYSTEM.**

[FR]

**SUPPORTS MURAUX RÉGLABLES  
PRÉMONTÉS OU NON AVEC CLIPS  
D'INSTALLATION.**



<b>S-210</b>	P420xH400xL800 mm	150 set	120 kg
<b>S-211</b>	P465xH400xL800 mm	150 set	160 kg
<b>S-213</b>	P550xH400xL800 mm	120 set	160 kg



# TYPE 2



INOX



COLOUR



CERTIFIED  
100-160 KG



**PLUS - M8 8.8**

450 mm

520 / 560 / 600 mm



2 EMME CLIMA

[IT]

**STAFFE UNIVERSALI REGOLABILI  
PREMONTATE E NON.**

[EN]

**ADJUSTABLE UNIVERSAL PRE-  
ASSEMBLED WALL BRACKETS  
AND NON.**

[FR]

**SUPPORTS MURAUX RÉGLABLES  
PRÉMONTÉS OU NON.**

		Zn	AISI 304		
<b>S-221</b>	P450xH400xL800 mm			120 set	100 kg
<b>S-281</b>	P450xH400xL800 mm	X	X	120 set	160 kg
<b>S-272*</b>	P520xH400xL800 mm	X	X	120 set	160 kg
<b>S-273*</b>	P560xH400xL800 mm			120 set	160 kg
<b>S-274*</b>	P600xH400xL800 mm	X		120 set	160 kg

\*Disponibile versione con barra L 1000 mm  
Available with crossbar L 1000 mm  
Disponible avec barre de L 1000 mm



# CLOCK TYPE 3

S-310  
420 mm

S-311  
465 mm

S-313  
550 mm

RAL  
9002

kg



COLOUR

CERTIFIED  
120-160 KG

2 EMME CLIMA



CLOCK SYSTEM

M8 8.8



1 ← → 2

[IT]

**STAFFE UNIVERSALI REGOLABILI  
PREMONTATE E NON CON AGGANCIO  
RAPIDO.**

[EN]

**ADJUSTABLE UNIVERSAL  
PRE-ASSEMBLED AND NON WALL  
BRACKETS WITH HOOK SYSTEM.**

[FR]

**SUPPORTS MURAUX RÉGLABLES  
PRÉMONTÉS OU NON AVEC CLIPS  
D'INSTALLATION.**



<b>S-310</b>	P420xH400xL800 mm	120 set	120 kg
<b>S-311</b>	P465xH400xL800 mm	120 set	160 kg
<b>S-313</b>	P550xH400xL800 mm	120 set	160 kg



# TYPE 3



INOX



COLOUR



CERTIFIED  
160 KG



**PLUS - M8 8.8**

450 mm

520 / 560 / 600 mm



2 EMME CLIMA

[IT]

**STAFFE UNIVERSALI REGOLABILI  
PREMONTATE E NON.**

[EN]

**ADJUSTABLE UNIVERSAL PRE-  
ASSEMBLED WALL BRACKETS  
AND NON.**

[FR]

**SUPPORTS MURAUX RÉGLABLES  
PRÉMONTÉS OU NON.**



AISI  
304



		AISI 304		
<b>S-381</b>	P450xH400xL800 mm		120 set	160 kg
<b>S-372*</b>	P520xH400xL800 mm	X	120 set	160 kg
<b>S-373*</b>	P560xH400xL800 mm		120 set	160 kg
<b>S-374*</b>	P600xH400xL800 mm	X versione barra 1000	120 set	160 kg

\*Disponibile versione con barra L 1000 mm  
Available with crossbar L 1000 mm  
Disponible avec barre de L 1000 mm





# TYPE 5



RAL  
9002

COLOUR



CERTIFIED  
160 KG



2 EMME CLIMA



[IT]

**STAFFE UNIVERSALI REGOLABILI  
PREMONTATE E NON.**

[EN]

**ADJUSTABLE UNIVERSAL PRE-  
ASSEMBLED WALL BRACKETS  
AND NON.**

[FR]

**SUPPORTS MURAUX RÉGLABLES  
PRÉMONTÉS OU NON.**



<b>S-581</b>	P450xH400xL850 mm	105 set	160 kg
<b>S-582</b>	P520xH400xL850 mm	105 set	160 kg
<b>S-564-1</b>	P600xH400xL960 mm	105 set	160 kg



# TYPE 5



COLOUR



CERTIFIED  
120-160 KG



2 EMME CLIMA

[IT]

**STAFFE UNIVERSALI REGOLABILI  
PREMONTATE E NON.**

[EN]

**ADJUSTABLE UNIVERSAL PRE-  
ASSEMBLED WALL BRACKETS  
AND NON.**

[FR]

**SUPPORTS MURAUX RÉGLABLES  
PRÉMONTÉS OU NON.**

<b>S-550</b>	P380xH400xL850 mm	105 set	160 kg
<b>S-551</b>	P480xH400xL850 mm	105 set	160 kg
<b>S-531*</b>	P450xH400xL850 mm	105 set	120 kg
<b>S-532*</b>	P530xH400xL850 mm	105 set	120 kg
<b>S-533*</b>	P550xH400xL850 mm	105 set	120 kg

\*Disponibile con barra da L 1000 mm  
Available with crossbar L 1000 mm  
Disponible avec barre de L 1000 mm



# HEAVY DUTY



COLOUR



CERTIFIED  
200-250-300 KG



2 EMME CLIMA



[IT]

**STAFFE INDUSTRIALI REALIZZATE  
PER SOSTENERE LE MACCHINE  
PIÙ PESANTI.**

[EN]

**HEAVY-DUTY WALL BRACKETS  
MADE TO HOLD HEAVIER UNITS.**

[FR]

**SUPPORTS MURAUX INDUSTRIELS  
ÉTUDIÉS POUR SUPPORTER LES  
MACHINES LES PLUS LOURDES.**

<b>S-672</b>	P520xH400 mm	112 set	300 kg
<b>S-673</b>	P560xH400 mm	112 set	300 kg
<b>S-674</b>	P650xH400 mm	112 set	200 kg

NEW

Semplici senza barra  
Simple without cross bar  
Simple sans barre

<b>S-572</b>	P520xH400xL850 mm	70 set	300 kg
<b>S-572-1</b>	P520xH400xL960 mm	70 set	300 kg
<b>S-573</b>	P560xH400xL850 mm	70 set	300 kg
<b>S-573-1</b>	P560xH400xL960 mm	70 set	300 kg
<b>S-575</b>	P700xH400xL850 mm	70 set	250 kg
<b>S-575-1</b>	P700xH400xL960 mm	70 set	250 kg

NEW NEW

Universali/Universal/Universel



# HEAVY DUTY SPECIAL



2 EMME CLIMA

KIT SUPER LOAD\*

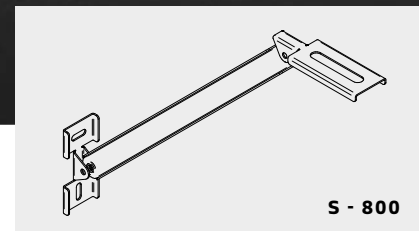

S - 800

[IT] **STAFFE INDUSTRIALI FORNITE CON PROLUNGHE DI ESTENSIONE REGOLABILI E/O KIT SUPER LOAD.**

[EN] **HEAVY-DUTY WALL BRACKETS SUPPLIED WITH EXTENDER AND/OR BRACING SUPER LOAD.**

[FR] **SUPPORTS MURAUX INDUSTRIELS FOURNIS AVEC EXTENSIONS RÉGLABLES ET/OU KIT SUPER LOAD.**

NEW

<b>S-680-1 SUPER LONG</b>	min P600xH400XL960 mm / max P640xH400xL960 mm	50 set	300 kg
<b>S-685-1 SUPER LOAD</b>	min P600xH400XL960 mm / max P640xH400xL960 mm	50 set	550 kg
<b>S-683-1 SUPER LONG</b>	min P600xH400XL960 mm / max P640xH400xL960 mm con 3 vertical / with 3 verticals arms / avec 3 bras verticaux		300 kg

KIT SUPER LOAD disponibile separatamente  
KIT SUPER LOAD available separately  
KIT SUPER LOAD disponible séparément

<b>S-800*</b>	P100xH280xL130 mm	5 set



# SUPER LIGHT

RAL  
9002



COLOUR

CERTIFIED  
100 KG



2 EMME CLIMA

[IT]

**STAFFE UNIVERSALI REGOLABILI  
PER UNITA' COMPATTE.  
NON PREMONTATE.**

[EN]

ADJUSTABLE UNIVERSAL WALL  
BRACKETS FOR SMALLER CONDENSING  
UNITS. NOT PREASSEMBLED.

[FR]

SUPPORTS MURAUX RÉGLABLES  
POUR LES UNITÉS PLUS COMPACTES.  
NON PRÉMONTÉS.



**S-410.01**

P420xH400xL700mm

240 set

100 kg



# TYPE 1



COLOUR



CERTIFIED  
120-160 KG



**PLUS - M8 8.8**  
420 / 465 mm

380 / 480 / 450 / 520 / 550 /  
560 / 600 mm



2 EMME CLIMA

[IT]

**STAFFE SEMPLICI PREMONTATE  
E NON.**

[EN]

**PRE-ASSEMBLED AND NON SIMPLE  
BRACKETS.**

[FR]

**SUPPORTS MURAUX SIMPLES  
PRÉMONTÉS OU NON.**

<b>S-110*</b>	P420xH400 mm	160 set	120 kg
<b>S-111*</b>	P465xH400 mm	160 set	160 kg
<b>S-113</b>	P550xH400 mm	150 set	160 kg

\*Con gancio clock  
With hook system/Avec clip d'installation

<b>S-181</b>	P450xH400 mm	160 set	160 kg
<b>S-172</b>	P520xH400 mm	120 set	160 kg
<b>S-173</b>	P560xH400 mm	120 set	160 kg
<b>S-174</b>	P600xH400 mm	120 set	160 kg

<b>S-050</b>	P380xH400 mm	112 set	120 kg
<b>S-051</b>	P480xH400 mm	112 set	120 kg



# SALDATE VERNICIATE



INOX



COLOUR



110-120-160  
180-200-350



E 80 mm



M 50/60 mm

[IT]

**STAFFE SALDATE VERNICIATE  
VELOCI E FACILI DA MONTARE.**

[EN]

**WELDED BRACKETS VARNISHED  
FAST AND EASY TO BE INSTALLED.**

[FR]

**SUPPORTS MURAUX SOUDÉS  
MONTAGE RAPIDE ET FACILE.**

<b>S-501</b>	P420xH300xL40 mm	168 SET	120 kg
<b>S-502</b>	P520xH300xL40 mm	168 SET	120 kg
<b>S-504</b>	P600xH400xL50 mm	50 SET	160 kg

Disponibile versione zincata a caldo o inox AISI 304 su richiesta.  
Available hot dip galvanized or AISI 304 stainless steel version upon request.  
Disponible galvanisé à chaud ou inox AISI 304 sur demande.

## SALDATE SPECIALI

SPECIAL WELDED BRACKETS/SUPPORTS MURAUX SOUDES SPECIAUX

<b>S-501M*</b>	P420xH400xL50 mm	200 kg
<b>S-502M*</b>	P520xH400xL50 mm	200 kg
<b>S-504M*</b>	P620xH400xL60 mm	200 kg
<b>S-503M*</b>	P650xH380xL60 mm	200 kg
<b>S-505M*</b>	P700xH500xL60 mm	180 kg
<b>S-506M*</b>	P800xH500xL60 mm	180 kg

<b>S-507M*</b>	P1100xH500xL60 mm	110 kg
<b>S-501E*</b>	P420xH400xL80 mm	350 kg
<b>S-502E*</b>	P520xH400xL80 mm	350 kg
<b>S-504E*</b>	P620xH400xL80 mm	350 kg
<b>S-505E*</b>	P800xH500xL80 mm	160 kg
<b>S-507E*</b>	P1100xH500xL80 mm	160 kg



# SPECIAL



RAL  
9002



COLOUR

100-120 KG

[IT]

**STAFFE SEMPLICI SOSPESSE PER BUNGALOW O CASE IN LEGNO CON BASE IN MURATURA.**

[EN]

EMBOSSED SIMPLE BRACKETS FOR BUNGALOWS OR WOODEN HOUSES WITH BRICK BASE.

[FR]

SUPPORTS SIMPLES SUSPENDUS POUR BUNGALOW OU MAISONS EN BOIS AVEC FONDATIONS BÉTON.



**S-662**

L520xH300+180 mm

96 SET

100 kg

[IT]

**STAFFE A SOSPENSIONE PER INSTALLAZIONE A SOFFITTO PREMONTATE.**

[EN]

PREASSEMBLED HANGING BRACKETS FOR CEILING INSTALLATION.

[FR]

SUPPORTS SUSPENDUS PREMONTÉS POUR INSTALLATION AU PLAFOND.



**S-665**

L450 (x2) x H800 mm

120 SET

120 kg

[IT]

**STAFFE A SOSPENSIONE PREMONTATE PER INSTALLAZIONE A SOFFITTO / TERRAZZI**

[EN]

HANGING BRACKETS PREASSEMBLED FOR CEILING / SMALL BALCONIES

[FR]

SUPPORTS SUSPENDUS PREMONTÉS POUR INSTALLATION AU PLAFOND / PETITS BALCONS



**S-667**

L450xH800 mm

120 SET

120 kg





# BACINELLE



## CONDENSATION TRAY / BAC DE RECUPERATION CONDENSATS

[IT]

### METALLO

Bacinella raccogli condensa completa di agganci, dotata di foro e piletta Ø 20 mm per lo scarico condensa. Adattabile a qualsiasi tipo di staffa e supporto a pavimento in metallo.

[EN]

### METAL

Metal tray for the collection of condensation water supplied with 2 hang supports, Ø 20 mm water outlet to connect drain pipe. Suitable to any kind of brackets in metal.

[FR]

### METAL

Bac de récupération condensats fourni avec fixations, raccord Ø 20 mm pour l'évacuation. Adaptable à tous les types de supports en métal.



<b>S-097-71</b>	L850xP390mm
<b>S-095-71</b>	L940xP390 mm
<b>S-096-71 HEAVY DUTY</b>	L940 x P420 mm
<b>S-093-71 HEAVY DUTY</b>	L1100 x P420 mm

2 EMME CLIMA

[IT]

### PLASTICA

Kit bacinella raccogli condensa universale in materiale plastico stabilizzato UV completo di aggancio. Piletta Ø16 mm, Ø18 mm, Ø20 mm inclusa. Adattabile a qualsiasi staffa.

[EN]

### PLASTIC

Plastic tray for the collection of condensation water made from rigid UV-stabilized plastic. Supplied with 2 hang supports suitable to any kind of brackets. Equipped with Ø16 mm, Ø18 mm, Ø20 mm water outlet to connect drain pipe.

[FR]

### PLASTIQUE

Bac de récupération condensats en plastique stabilisé UV. Fourni avec fixations et raccords Ø16 mm, Ø18 mm, Ø20 mm. Adaptable à tous types de supports.



<b>P-098-01</b>	L790xP390 mm
<b>P-099-01</b>	L940 x P420 mm



# CAVI SCALDANTI

## HEATING CABLES / CÂBLES CHAUFFANTS

[IT]

### NO-FROST CON TERMOSTATO

Cavo scaldante contro il congelamento delle apparecchiature, a protezione dei tubi. Dotato di termostato antigelo che attiva il circuito solamente in presenza di una data temperatura permettendo un notevole risparmio energetico. Fornito già tagliato a misura e pronto all'uso. Non può essere accorciato.

[EN]

### NO-FREEZING WITH THERMOSTAT / ANTIGEL

Heating cable against freezing appliances, to protect pipes. Thanks to the integrated no-freezing thermostat the circuit switches-on automatically under a specific temperature. Supplied cut and ready to be used. It cannot be shortened.

[FR]

### AVEC THERMOSTAT

Câble chauffant contre le gel des équipements, protège la tuyauterie. Doté d'un thermostat contre le gel qui active le circuit seulement en-dessous d'une température spécifique permettant ainsi une économie d'énergie. Fourni déjà coupé et prêt à l'emploi. Ne peut être raccourci.



<b>9898-010</b>	1 m	1 m	2 m
<b>9898-012</b>	2 m	1 m	3 m
<b>9898-013</b>	3 m	1 m	4 m
<b>9898-015</b>	5 m	1 m	6 m

\*Temperatura di utilizzo -60°/+130°  
Working temperature -60°/+130°  
Température d'usage -60°/+130°

A = Parte scaldante/Heating part/Partie chauffante  
B = Parte fredda/Cold part/Partie froide  
C = Lunghezza totale/Total length/Longueur totale

[IT]

### IN FOGLIO DI ALLUMINIO

Cavo scaldante inserito su fogli di alluminio per l'utilizzo in ambienti umidi ed in immersione. Su richiesta può essere dotato di autoadesivo, termostato o limitatore di temperatura.

[EN]

### ON ALUMINIUM FOIL

Heating cable inside two aluminium foils to be used in highly humid environments and immersed. If required, it can be produced with a sticker application, thermostat and or safety temperature limiter.

[FR]

### DANS FEUILLES D'ALUMINIUM

Câble chauffant inséré entre deux feuilles d'aluminium pour une utilisation dans les environnements humides et/ou en immersion. Sur demande, il peut être fourni avec adhésif, thermostat ou limiteur de température.



<b>9898-020</b>	L940x400 mm

\*Temperatura di utilizzo -60°/+130°  
Working temperature -60°/+130°  
Température d'usage -60°/+130°



# ANTIVIBRANTI RAINBOW

## ANTIVIBRATION DAMPERS / KIT ANTI-VIBRATILES

[IT]

### ANTIVIBRANTI TELESCOPICI CON MOLLA INTERNA

Progettati per carichi diversi forniti in doppio colore per distinguere le resistenze al carico.

[EN]

### TELESCOPIC ANTIVIBRATION DAMPERS WITH INTERNAL SPRING

Designed for different loads supplied in two different colours to distinguish their resistance.

[FR]

### PLOTS ANTI-VIBRATILES TÉLÉSCOPIQUES AVEC RESSORT INTERNE

Projetés pour différentes charges et livrés en 2 coloris pour distinguer leur résistance.



<b>9898-120</b>	azzurri/verdi - light blue/green - bleu d'azur/vert	4 pz (1 kit)	da 30 a 55 kg*
<b>9898-121</b>	azzurri/gialli - light blue/yellow - bleu d'azur/jaune	4 pz (1 kit)	da 50 a 80 kg*
<b>9898-122</b>	bianchi/rossi - white/red - blanc/rouge	4 pz (1 kit)	da 70 a 120 kg*

Disponibile display da 18 kit  
Available counter with 18 kits  
Présentoir de 18 kits disponible

\*Portata per kit  
Load capacity per kit  
Charge par kit

2 EMME CLIMA

[IT]

### ANTIVIBRANTI TELESCOPICI

Realizzati con elastomeri termoplastici speciali resistenti al carico.

[EN]

### TELESCOPIC ANTI-VIBRATION DAMPERS

Realized with special thermoplastic elastomer resistant to different loads.

[FR]

### PLOTS ANTI-VIBRATILES TÉLÉSCOPIQUES

Réalisés avec élastomères thermoplastiques résistants à différentes charges.



<b>9898-130</b>	verde/green/vert - 35 shore	4 pz (1 kit)	da 35 a 100 kg*
<b>9898-131</b>	beige/beige/beige - 45 shore	4 pz (1 kit)	da 90 a 200 kg*
<b>9898-132</b>	rosso/red/rouge - 60 shore	4 pz (1 kit)	da 100 a 350 kg*
<b>9898-133</b>	nero/black/noir - 75 shore	4 pz (1 kit)	da 180 a 450 kg*

Disponibile display da 18 kit  
Available counter with 18 kits  
Présentoir de 18 kits disponible

\*Portata per kit  
Load capacity per kit  
Charge par kit



# ANTIVIBRANTI PER STAFFE

ANTIVIBRATION DAMPERS FOR WALL BRACKETS  
KIT ANTI-VIBRATILES POUR SUPPORTS MURAUX

[IT]

IN GOMMA NATURALE  
COMPONENTI 4 ANTIVIBRANTI  
CON RELATIVE RONDELLE E DADI.





[EN]

MADE OF SOFT NATURAL RUBBER,  
CONTAINING 4 DAMPERS, WASHERS  
AND NUTS.

[FR]

EN CAOUTCHOUC NATUREL  
COMPRENANT 4 PLOTS, RONDELLES  
ET ÉCROUS.

FILETTO Ø M8  
MA Ø8 THREAD / FILETAGE MA Ø8

			
<b>9898-024</b>	L39xH22 mm	20 kit	80 kg*







			
<b>9898-023</b>	L39xH22 mm	20 kit	50 kg*



			
<b>9898-028</b>	L30xH20 mm	20 kit	70 kg*



			
<b>9898-027</b>	L40xH40 mm	20 kit	80 kg*



\*Portata per kit / Load capacity per kit / Charge par kit

# INNOVAZIONE: FOCUS POMPE DI CALORE

INNOVATION: FOCUS ON HEAT PUMPS  
INNOVATION: FOCUS SUR LES POMPES À CHALEUR



**QUI TROVI I PRODOTTI  
FATTI SU MISURA PER TE.**

**HAVE A LOOK AT OUR  
TAYLOR MADE  
PRODUCTS SUITABLE  
FOR YOUR NEEDS.**

**RETROUVE LES  
PRODUITS FAITS SUR  
MESURE POUR TOI.**

2 EMME CLIMA



[↑] S-575 - p.18

## HEAVY DUTY SUPER LONG

[L] S-683-1 - p.19

Staffa con **3 verticali** per l'installazione di unità a 3 appoggi.

Heavy Duty Wall brackets with **3 vertical** arms for the installation of 3 feet units.

Supports Heavy Duty avec **3 bras verticaux** pour l'installation des machines à 3 pieds.



## HEAVY DUTY

Staffa con barra o semplice con braccio orizzontale da **700 mm**.

Simple or with sliding bar wall brackets with **700 mm** horizontal arms.

Supports simples ou avec barre avec des bras horizontaux de longueur **700 mm**.



[→] S-800 - p.19

## SUPER LOAD KIT

**per sostenere i carichi più pesanti!**

**BRACING SUPER LOAD** for heavier loads!

**Extensions SUPER LOAD** pour des charges supérieures!

[W] S-836-71.3 - p.30



## KIT HEAT PUMPS

Kit Pompe di calore con **2 o 3 supporti in gomma Brooklyn** completo di bacinella.

Kit Heat pumps with **2 or 3 Brooklyn bases** and a metal tray.

Kit Pompes à chaleur avec **2 ou 3 Brooklyn bases** et bac récupération condensats.

## KIT 3 BROOKLYN

[L] S-636.3 - p. 32

**Kit 3 Brooklyn 600 mm** forniti in una scatola unica.

**Kit 3 Brooklyn 600 mm** supplied in a single box.

**Kit 3 Brooklyn 600 mm** fourni dans un emballage unique.





# INSTALLAZIONI A PAVIMENTO

GROUND INSTALLATION  
INSTALLATION AU SOL





# KIT HEAT PUMPS

SBR

RAL 9002



COLOUR

300 KG



2 EMME CLIMA

[IT]

## KIT D'INSTALLAZIONE PER POMPE DI CALORE

Completo di bacinella per lo scarico condensa con piletta Ø20 mm e supporti in gomma Brooklyn L600 mm.

[EN]

## INSTALLATION KIT FOR HEAT PUMPS

Supplied with tray for the collection of condensation water with Ø20 mm outlet and Brooklyn rubber bases L600 mm.

[FR]

## KIT D'INSTALLATION POUR POMPES À CHALEUR

Équipé d'un bac de récupération condensats avec raccord Ø20 mm et supports en gomme Brooklyn L600 mm.

NEW

<b>S-836-71*</b>	Hmin 290/max 340 mm xP500 mm	25 set	300 kg
<b>S-836-71.3</b>	Hmin 290/max 340 mm xP500 mm Modello con tre supporti Model with 3 supports Modèle avec 3 supports		300 kg

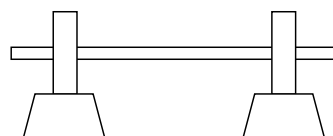

min 290 / max 340 mm

Fornito con bacinella  
supplied with condensate tray  
fourni avec bac de récupération  
L940 x P390 mm

\*Scatola unica  
Single box  
Emballage unique



# REGULAR

Zn

RAL  
9002



COLOUR

200 KG



2 EMME CLIMA



9898-025

[IT]

## SUPPORTO A PAVIMENTO PER UNITA' ESTERNE

Regolabile in altezza e lunghezza.  
Fornito premontato.

[EN]

## GROUND SUPPORT FOR EXTERNAL UNITS

Adjustable in length and height.  
Supplied pre-assembled.

[FR]

## SUPPORT AU SOL POUR LES UNITÉS EXTERNES

Réglable en hauteur et en longueur.  
Fourni pré-monté.



<b>S-651P*</b>	min L510xH350xP450 mm / max L860xH500xP450 mm	50 pz	200 kg
<b>S-652P</b>	Versione completa di antivibranti / With dampers / Avec plots antivibratiles 9898-025 p.38		
<b>S-655P</b>	min L450xH350xP500 mm / max L820xH500xP500 mm	50 pz	200 kg
<b>S-655-11</b>	Versione completa di bacinella in metallo / With metal tray / Avec bac metallique S-097-71 p.24		

\*Disponibile versione zincata a caldo  
Hot-dip galvanised version available  
Version zinguée à chaud disponible





# BROOKLYN BASE

H100



SBR

AI



100↔500 KG

**TiRAN**  
SUPPORT SYSTEMS



**ESTENSIONE**  
RISER / RÉHAUSSE



P200 mm

**VITE E DADO M10**  
M10 BOLT AND NUT / VIS ET ÉCROU M10



20x15 mm



41x21 mm

2 EMME CLIMA

[IT]

**BASE A PAVIMENTO IN GOMMA RICICLATA SBR CON PROFILO IN ALLUMINIO.**

[EN]

**GROUND BASE MADE FROM SBR RECYCLED RUBBER AND ALUMINIUM STRUT.**

[FR]

**SUPPORT AU SOL EN CAOUTCHOUC RECYCLÉ SBR ET PROFIL ALUMINIUM.**

20x15 mm	41x21 mm	RISER				
S-632	S-732	S-742	L250xH95xP150 mm	4 pz	216 pz	100* kg
S-634	S-734	S-744	L400xH95xP150 mm	2 pz	162 pz	200* kg
S-636	S-736	S-746	L600xH95xP150 mm	2pz	108 pz	500* kg
S-630	S-730	S-740	L1000xH95xP150 mm	2pz	60 pz	500* kg
S-642	--	--	L1200xH95xP150 mm	2pz	60 pz	500* kg
<b>S-636.3**</b>	<b>S-736.3**</b>	<b>S-746</b>	L600xH95xP150 mm	3pz	96 pz	500* kg

**\*Portata per pezzo**  
Load capacity per piece  
Charge par pièce

**\*\*Disponibile versione per installazione con 3 supporti**  
Available version with 3 supports  
Disponible version pour installation à 3 supports

NEW



# BROOKLYN HIGH-RISE

H150



SBR

AI



500 KG

**TiRAN**  
SUPPORT SYSTEMS



2 EMME CLIMA

**VITE E DADO M10**  
M10 BOLT AND NUT  
VIS ET ÉCROU M10



20x15 mm

[IT]

**BASE A PAVIMENTO CON ALTEZZA 150 MM IN GOMMA RICICLATA SBR.**

[EN]

**GROUND BASE 150 MM HIGH MADE FROM SBR RECYCLED RUBBER.**

[FR]

**SUPPORT AU SOL HAUTEUR 150 MM EN CAOUTCHOUC RECYCLÉ SBR.**

20x15 mm				
<b>S-646</b>	L600xH150xP200 mm	2 pz	80 pz	500* kg
<b>S-643</b>	L1200xH150xP200 mm	2 pz	40 pz	500* kg

**\*Portata per pezzo**  
Load capacity per piece  
Charge par pièce



# BROOKLYN EXTRA

H100



SBR

AI



200->500 KG

**TIRAN**  
SUPPORT SYSTEMS



2 EMME CLIMA

**VITE E DADO M10**  
M10 BOLT AND NUT  
VIS ET ÉCROU M10

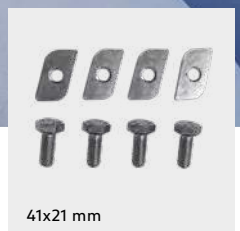

[IT]

**BASE A PAVIMENTO EXTRA LARGE  
IN GOMMA RICICLATA SBR.**

[EN]

**EXTRA LARGE GROUND BASE MADE  
FROM SBR RECYCLED RUBBER.**

[FR]

**SUPPORT AU SOL EXTRA LARGE  
EN CAOUTCHOUC RECYCLÉ SBR.**

41x21 mm				
<b>S-754</b>	L400xH95xP200 mm	2 pz	120 pz	200* kg
<b>S-756</b>	L600xH95xP200 mm	2 pz	80 pz	500* kg
<b>S-750</b>	L1000xH95xP200 mm	2 pz	40 pz	500* kg

**\*Portata per pezzo**  
Load capacity per piece  
Charge par pièce

# BROOKLYN MINI



200 KG

**TiRAN**  
SUPPORT SYSTEMS

[IT]





**MINI BASE A PAVIMENTO REALIZZATA IN GOMMA RICICLATA SBR.**

[EN]

MINI GROUND SUPPORT BASE MADE FROM SBR RECYCLED RUBBER.

[FR]

SUPPORT AU SOL MINI EN CAOUTCHOUC RECYCLÉE SBR.

41x21 mm				
<b>S-764</b>	L400xH45xP200 mm	240 pz	2 pz	200* kg
<b>S-766</b>	L600xH45xP200 mm	160 pz	2 pz	200* kg

\*Portata per pezzo  
Load capacity per piece  
Charge par pièce



**FORNITE CON VITE E DADO M10**  
SUPPLIED WITH M10 BOLT AND NUT  
FOURNIS AVEC VIS ET ÉCROU M10

**H50**

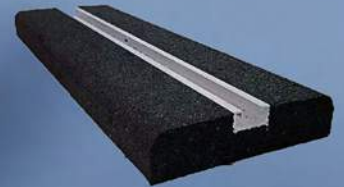

2 EME CLIMA

# BROOKLYN SYSTEM



220 KG

**TiRAN**  
SUPPORT SYSTEMS

[IT]





**BASE COMPOSTA DA DUE STRATI DI GOMMA RIGIDA RICICLATA E DA UNO STRATO INTERMEDIO AMMORTIZZANTE.**

[EN]

RUBBER SUPPORT MADE FROM TWO RIGID RECYCLED RUBBER LAYERS AND FROM A SHOCK ABSORBING MIDDLE LAYER.

[FR]

SUPPORT COMPOSÉ DE DEUX COUCHES DE CAOUTCHOUC RIGIDE ET D'UNE COUCHE INTERMÉDIAIRE AMORTISSANTE.

				
<b>S-719</b>	L190xH90xP140 mm	320 pz	8 pz	220* kg
<b>S-729</b>	L290xH90xP140 mm	320 pz	8 pz	220* kg

\*Portata per pezzo  
Load capacity per piece  
Charge par pièce

**H90**





# BASI A PAVIMENTO

## GROUND SUPPORTS/SUPPORTS AU SOL

[IT]

**SUPPORTI A CONO REALIZZATI IN PVC RIGIDO AUTOESTINGUENTE.**

[EN]

CONE SUPPORTS MADE OF RIGID PVC SELF-EXTINGUISHING.

[FR]

SUPPORTS SOL CONIQUES RÉALISÉS EN PVC AUTO-EXTINGUIBLE.

<b>9898-037-01</b>	L105xH95 mm	12 kit	500* kg
<b>C-037</b>	Piastra antivibrante/ anti-vibration plate/ plaque antivibratoire	24 pz	



[IT]

**BASI A PAVIMENTO REALIZZATE IN POLIPROPILENE.**

[EN]

GROUND SUPPORTS MADE OF POLYPROPYLENE.

[FR]

BASES RÉALISÉES EN POLYPROPYLÈNE.

<b>P-033-01</b>	L450XH78 mm	24 pz	100* kg



[IT]

**BASI A PAVIMENTO REALIZZATE IN PVC RIGIDO.**

[EN]

GROUND SUPPORTS PRODUCED WITH HIGH QUALITY PVC.

[FR]

BASES RÉALISÉES EN PVC RIGIDE.

<b>P-032-01</b>	L350xH80mm	24 pz	140* kg
<b>P-031-01</b>	L450xH80mm	24 pz	140* kg
<b>P-030-01</b>	L1000xH80mm	4 pz	140* kg
<b>P-036-01</b>	L350xH100mm	24 pz	160* kg
<b>P-035-01</b>	L450xH100mm	24 pz	160* kg
<b>P-034-01</b>	L1000xH100mm	4 pz	160* kg



\*Portata per pezzo  
Load capacity per piece  
Charge par pièce

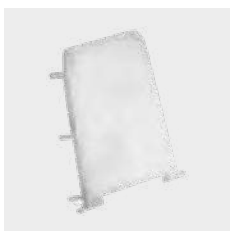

### TAPPI CLOSING CAP / COUVERCLE

<b>P-029-01</b>	L80xH80mm	24 pz
<b>P-028-01</b>	L100xH100mm	24 pz



# METAL BOX



COLOUR

[IT]

**PROTEZIONE IN METALLO PER PREVENIRE ATTI VANDALICI ED EVENTUALI DANNI ACCIDENTALI.**

[EN]

PROTECTION GUARD MADE TO PREVENT VANDALISM ACTS AND ACCIDENTAL DAMAGES.

[FR]

COFFRE DE PROTECTION POUR PRÉVENIR TOUT ACTES DE VANDALISME OU DOMMAGES ACCIDENTELS.

<b>S-900-1</b>	Small	L900xH750xP450 mm	1 pz
<b>S-901-1</b>	Intermediate	L1050xH950xP650 mm	1 pz
<b>S-902-1</b>	Medium	L1150xH1200xP650 mm	1 pz
<b>S-903-1</b>	Large	L1150xH1550xP650 mm	1 pz
<b>S-904-1</b>	Extra large	L1150xH2000xP850 mm	1 pz

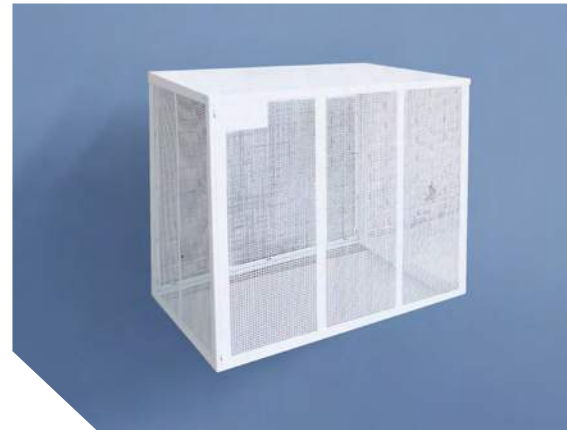

Colori diversi disponibili su richiesta (Min. 20 pz)  
Different colours available upon request (Min. Q.ty 20 pcs)  
Disponible en différents coloris sur demande (Min. Q.té 20 pcs)

[IT]

**PANNELLO POSTERIORE**

[EN]

BACK PANEL

[FR]

PANNEAU POSTÉRIEUR

<b>S-900-3</b>	Small	L900xH750 mm	1 pz
<b>S-901-3</b>	Intermediate	L1050xH950 mm	1 pz
<b>S-902-3</b>	Medium	L1150xH1200 mm	1 pz
<b>S-903-3</b>	Large	L1150xH1550 mm	1 pz
<b>S-904-3</b>	Extra large	L1150xH2000 mm	1 pz

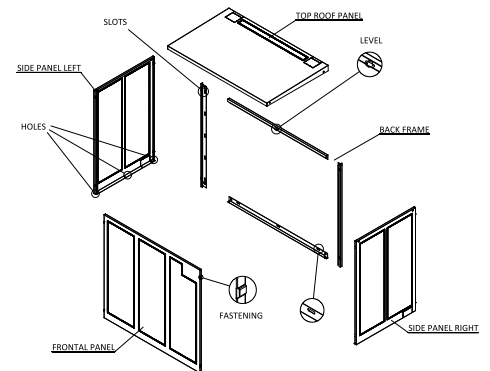

[IT]

**BACINELLA RACCOGLI CONDENSA**

[EN]

CONDENSATION WATER TRAY

[FR]

BAC DE RECUPERATION

<b>S-900-4</b>	Small	L900xH450 mm	1 pz
<b>S-901-4</b>	Intermediate	L1050xH650 mm	1 pz
<b>S-902-4</b>	Medium / Large	L1150xH650 mm	1 pz
<b>S-904-4</b>	Large	L1150xH850 mm	1 pz





# ANTIVIBRANTI A PAVIMENTO

## GROUND ANTIVIBRATION DAMPERS / KIT ANTI-VIBRATILES AU SOL

[IT]

### TELESCOPICI

Antivibranti telescopici composti da dischi in acciaio zincato rivestiti in elastomero termoplastico e da un elemento elastico interno. Fornito con piastra d'appoggio e viteria.

[EN]

### TELESCOPIC

Telescopic antivibration dampers made of steel discs galvanized coated in thermoplastic elastomer and of an internal elastic element. Supplied with fixing plate and screws.

[FR]

### TÉLÉSCOPIQUES

Plots anti-vibratiles télescopiques composés de disques en acier galvanisé revêtus en élastomère thermoplastique et d'un élément élastique interne. Fournis avec plaque d'appui et visserie.

<b>9898-146</b>	L40xH40 mm - M8x22	4 pz (1 kit)	90-200 kg*
<b>9898-166</b>	L60xH50 mm - M10x30	4 pz (1 kit)	120-360 kg*



[IT]

### A PAVIMENTO

Kit antivibranti in gomma nera naturale comprendenti 4 antivibranti con relative rondelle e dadi.

[EN]

### GROUND

Anti-vibration dampers made of soft black natural rubber, containing 4 dampers, washer and nuts.

[FR]

### SOL

Kit anti-vibrations en caoutchouc noir naturel comprenant 4 patins antivibrations, rondelles et écrous.

### FILETTO Ø M8 MA Ø8 THREAD / FILETAGE MA Ø8

<b>9898-026</b>	L40xH40 mm	20 kit	70 kg*



### FILETTO Ø M8 MA Ø8 THREAD / FILETAGE MA Ø8

<b>9898-025</b>	L48xH20 mm	20 kit	80 kg*



### FILETTO Ø M10 MA Ø10 THREAD / FILETAGE MA Ø10

<b>9898-014</b>	L56xH20 mm	20 kit	100 kg*



\*Portata per kit / Load capacity per kit / Charge par kit

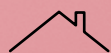

# INSTALLAZIONI A TETTO

ROOF INSTALLATION

INSTALLATION SUR TOIT







# STAFFA A TETTO

ROOF BRACKET/ SUPPORT DE TOITURE

RAL  
9002



COLOUR 80-150 KG



2 EMME CLIMA

[IT]

## STAFFA REGOLABILE IDONEA PER L'INSTALLAZIONE SU TETTO

Inclinazione da 15° a 30° in base alla pendenza del tetto.

[EN]

## ADJUSTABLE BRACKET FOR ROOF INSTALLATION

Adjustable inclination from 15° up to 30° according to the roof slope.

[FR]

## SUPPORT RÉGLABLE CONÇU POUR L'INSTALLATION SUR TOIT INCLINÉ

Réglable de 15° à 30° selon l'inclinaison du toit.



S-661



L850xP520 mm



70 set



15°=80 kg - 30°=150 kg



# STAFFE SOLARI A TETTO

AISI 304 Zn

INOX

## SOLAR BRACKETS

## SUPPORTS DE FIXATION PANNEAUX SOLAIRES

[IT]

### STAFFA REGOLABILE UNIVERSALE PER TETTO

Disponibile in acciaio inox AISI 304 e zincato a caldo conforme a UNI 1461. Viteria inclusa. Fornita premontata.

[EN]

### ADJUSTABLE UNIVERSAL BRACKET FOR THE INSTALLATION OF SOLAR PANELS

Stainless steel AISI 304 and Hot-dip galvanised versions available in compliance with uni 1461. Screws included. Preassembled.

[FR]

### SUPPORT UNIVERSEL RÉGLABLE POUR L'INSTALLATION DES PANNEAUX SOLAIRES

Les versions en acier inox AISI 304 et zingué à chaud conforme à la norme UNI 1461 sont disponibles. Visserie incluse. Fourni prémonté.

### 232X207 MM

<b>ACCIAIO INOX</b> F52-251-40	L232xH min135-max207 xP50 mm	8 pz
<b>ACCIAIO ZINCATO</b> F52-251-76	L232xH min135-max207 xP50 mm	8 pz



### 174X134 MM

<b>ACCIAIO INOX</b> F52-253-40	L174xH min93-max134 xP130 mm	8 pz
<b>ACCIAIO ZINCATO</b> F52-253-76	L174xH min93-max134 xP130 mm	8 pz



### RIBASSATA 330X121 MM

<b>ACCIAIO INOX</b> F52-256-40	L330xH min89-max121 xP32 mm	8 pz
<b>ACCIAIO ZINCATO</b> F52-256-76	L330xH min89-max121 xP32mm	8 pz





# GIANT STANDARD FRAME

PA6  
GF30

SDZ

Zn



PLASTIC  
FOOT

500 <- 1500 KG

**TIRAN**  
SUPPORT SYSTEMS



2 EMME CLIMA



[IT]

## TELAIO MODULARE STANDARD

Componibile a 4, 6 o 8 piedi indipendenti 300x300 mm e profili in acciaio zincato Sendzimir o zincato a caldo 41x41 mm.

[EN]

## STANDARD MODULAR FRAME

Available with 4, 6 or 8 independent feet and 41x41 mm Sendzimir galvanised or hot-dip galvanised steel struts.

[FR]

## CHÂSSIS MODULABLE STANDARD

Composé de 4, 6 ou 8 pieds indépendants 300x300 mm et profils galvanisés Sendzimir ou zingués à chaud 41x41 mm.

<b>GIANT 4 T-610</b>	1200 mm - 47.25 inch	1000 mm - 39.37 inch	270/390 mm - 10.63/15.35 inch	500 kg
<b>GIANT 6 T-615</b>	1200 mm - 47.25 inch	2000 mm - 78.74 inch	270/390 mm - 10.63/15.35 inch	1000 kg
<b>GIANT 8 T-618</b>	1200 mm - 47.25 inch	3000 mm - 118.11 inch	270/390 mm - 10.63/15.35 inch	1500 kg
<b>EXTENSION KIT T-620</b>	1200 mm - 47.25 inch	1000 mm - 39.37 inch	270/390 mm - 10.63/15.35 inch	500 kg

Profili da 1500 mm disponibili  
1500 mm struts available  
Profils de 1500 mm disponibles



# BIG GIANT

PA6  
GF30

SDZ

Zn



PLASTIC  
FOOT

500<-1500 KG

**TiRAN**  
SUPPORT SYSTEMS



2 EMME CLIMA



T-625

**NEW**

[IT]

## TELAIO MODULARE STANDARD ALTO

Componibile a 4, 6 o 8 piedi indipendenti 300x300 mm, profili in acciaio zincato Sendzimir o zincato a caldo 41x41 mm e controventature di supporto.

[EN]

## HIGH MODULAR FRAME

Available with 4,6 or 8 independent feet, 300x300 mm Sendzimir galvanised or hot-dip galvanised steel struts and bracing system.

[FR]

## CHÂSSIS MODULABLE CONFORME AU DTU 43.1

Composé de 4,6 ou 8 pieds indépendants 300x300 mm, profils galvanisés Sendzimir ou galvanisés à chaud 41x41 mm et système de contreventements.

<b>T-650</b>	1200 mm - 47.25 inch	1000 mm - 39.37 inch	710/820 mm - 27.95/32.28 inch	500 kg
<b>T-655</b>	1200 mm - 47.25 inch	2000 mm - 78.74 inch	710/820 mm - 27.95/32.28 inch	1000 kg
<b>T-658</b>	1200 mm - 47.25 inch	3000 mm - 118.11 inch	710/820 mm - 27.95/32.28 inch	1500 kg
<b>T-625 EXTENSION KIT</b>	1200 mm - 47.25 inch	1000 mm - 39.37 inch	710/820 mm - 27.95/32.28 inch	500 kg



# BRIDGE

SDZ

PA6  
GF30

PLASTIC  
FOOT

**TiRAN**  
SUPPORT SYSTEMS

[IT]

## SISTEMA REALIZZATO PER IL SOSTEGNO DI CANALIZZAZIONI, TUBAZIONI E CONDOTTE

Fornito con piedi 300x300mm, tappetini antivibranti e fissaggi.

[EN]

SOLUTION MADE TO SUPPORT DUCTS, PIPEWORKS AND CABLES

Supplied with 300x300 mm feet, anti-vibration pads and fixings.

[FR]

SOLUTION RÉALISÉE AFIN DE SOUTENIR LES CANALISATIONS ET TUYAUTERIE

Fourni avec pieds 300x300 mm, tapis anti-vibratiles et fixations.

<b>T-621</b>	600 mm - 23.62 inch	240/624 mm - 9.45/24.54 inch	400 kg
<b>T-622</b>	Senza profili / Without struts / Sans profils		



# HIGH LOAD KIT

**TiRAN**  
SUPPORT SYSTEMS

[IT]

## SOLUZIONE PER IL SUPPORTO DI GRANDI IMPIANTI CON PIASTRA DI ALLOGGIAMENTO MACCHINA

Completo di piedi 300x300 mm, regolabile in altezza.

[EN]

SOLUTION FOR SUPPORTING HEAVY UNITS

Supplied with mounting plate and 300x300 mm feet, adjustable height.

[FR]

SOLUTION POUR SOUTENIR LES GRANDES INSTALLATIONS

Avec plaque de support, complétée par des pieds 300x300 mm, réglable en hauteur.

				<b>RIPARTITORE SPLITTER/REPARTITEUR</b>
<b>T-850</b>	312 mm 12.28 inch	652 mm 25.67 inch	228/353 mm 8.98/13.90 inch	No
<b>T-851</b>	470 mm 18.50 inch	940 mm 37.00 inch	287/412 mm 11.30/16.22 inch	Metal



[IT]

## RIPARTITORE IN ACCIAIO ZINCATO COMPLETO DI TAPPETO ANTIVIBRANTE PER UNA MAGGIORE DISTRIBUZIONE DEI CARICHI.

[EN]

METAL SPLITTER WITH ANTIVIBRATION MAT AVAILABLE FOR AN HIGHER LOAD SPREAD.

[FR]

RÉPARTITEUR DE CHARGE EN ACIER GALVANISÉ ET TAPIS ANTI-VIBRATILE DISPONIBLE POUR UNE MEILLEURE REPARTITION DU POIDS.

<b>T-905</b>	L460xP460 mm - 18x18 inch
<b>T-906</b>	L600xP600 mm - 23.62x23.62 inch
<b>T-909</b>	L940xP470 mm - 37x18.50 inch





# ACCESSORI DI RICAMBIO

**TiRAN**  
SUPPORT SYSTEMS

## SPARE PARTS/ACCESSOIRES

[IT]

### BACINELLA

Bacinella completa di staffe di aggancio per il fissaggio su Giant 4 Standard Frame.

[EN]

### METAL TRAY

Metal tray supplied with hang supports suitable for Giant 4 Standard Frame.

[FR]

### BAC À CONDENSATS

Bac à condensats fourni avec crochets pour fixation sur Giant 4 Standard Frame.



**S-094-71**

L650xP1050 mm - 25.60x41.33 inch

[IT]

### PIEDI IN PA6 GF30

Piedi indipendenti per innesto rapido di profili 41x41 mm o 40x40mm.

[EN]

### PA6 GF30 FEET

Independent feet for a quick insertion in 41x41 or 40x40 mm struts.

[FR]

### PIEDS EN PA6 GF30

Pieds independants pour insertion rapide dans profils 41x41 ou 40x40 mm.



Kit con 2 piedi, 2 tappeti antivibranti, 2 spinotti regolabili e viteria di fissaggio / kit with 2 feet, 2 antivibration mats, 2 adjustable legs and fixings / kit composé par 2 pieds, 2 tapis anti-vibratiles et 2 jambes réglables avec visserie

<b>T-610-1</b>	300 mm - 12 inch	300 mm - 12 inch	270/390 mm - 10.63/15.35 inch	600 kg per piede/foot/ pied
<b>T-650-1</b>	300 mm - 12 inch	300 mm - 12 inch	710/820 mm - 27.95/32.28 inch	300 kg per piede/foot/ pied



**T-711**

kit 2 piedi con tappeti antivibranti / kit 2 feet with antivibration mats / Kit composé par 2 pieds avec tapis anti-vibratiles

300 mm 12 inch	300 mm 12 inch	85 mm 3.35 inch
-------------------	-------------------	--------------------

NEW



# PROFILI

## BARS/PROFILS

[IT]

**PROFILO IN ACCIAIO ZINCATO SENDZIMIR O A CALDO CON TAPPI DI CHIUSURA**

[EN]

SENDZIMIR OR HOT DIP GALVANISED STEEL STRUTS WITH END CAPS

[FR]

PROFILS EN ACIER ZINGUÉ SENDZIMIR OU À CHAUD AVEC BOUCHONS DE FINITION

<b>B-840</b>	1000 mm - 39 inch	2 pz (1 kit)
<b>B-845</b>	2000 mm - 78.74 inch	2 pz (1 kit)
<b>B-848</b>	3000 mm - 118.11 inch	2 pz (1 kit)



<b>B-850</b>	kit 2 profili 1200 mm con viteria di giunzione e tappi di chiusura/ kit 2 struts 1200 mm with H-clamp and plastic end caps/ kit profils 1200 mm avec H de fixation et bouchons de finition en plastique	2 pz (1 kit)
	1200 mm - 47.24 inch	
<b>B-852</b>	kit 2 profili 1200 mm + 1000 mm con viteria di giunzione e tappi di chiusura/ kit 2 struts 1200 mm + 1000 mm with H-clamp and plastic end caps/ kit profils 1200mm + 1000 mm avec H de fixation et bouchons de finition en plastique	4 pz (1 kit)
	1200 mm - 47.24 inch	
	1000 mm - 39 inch	



NEW



# ANTIVIBRANTI

## ANTIVIBRATION DAMPERS / KIT ANTI-VIBRATILES

[IT]

**TELESCOPICI**

Antivibranti telescopici composti da dischi in acciaio zincato rivestiti in elastomero termoplastico e da un elemento elastico interno.

[EN]

**TELESCOPIC**

Telescopic antivibration dampers made of steel discs galvanized and coated in thermoplastic elastomer and of an elastic element.

[FR]

**TÉLÉSCOPIQUES**

Kit plots anti-vibratiles télescopiques composés de plaques en acier galvanisé et revêtus d'élastomère thermoplastique et d'un élément élastique intérieur.

<b>9898-141</b>	L40xH40 mm - M8x22	4 pz (1 kit)	90-200 kg*
<b>9898-161</b>	L60xH50 mm - M10x30	4 pz (1 kit)	120-360 kg*



\*Portata per kit  
Load capacity per kit  
Charge par kit



# TAPPETINI ANTIVIBRANTI

**TiRAN**  
SUPPORT SYSTEMS

## ANTIVIBRATION PADS/TAPIS ANTI-VIBRATILES

[IT]

### TAPPETO ANTIVIBRANTE IN GOMMA A 3 STRATI

Tappeto in gomma con schiuma composita nel centro. Studiato per eliminare le vibrazioni e ridurre il livello di rumore.

[EN]

### ANTI-VIBRATION PAD WITH 3 LAYERS

Rubber pad with special composite foam centre. Designed to eliminate vibrations and reduce noise levels.

[FR]

### TAPIS ANTI-VIBRATILE À 3 COUCHES

Tapis en gomme avec mousse composite au centre. Étudié pour réduire les vibrations et le bruit.



<b>T-930</b>	51x51x22 mm - 2x2x0.80 inch	48 pz
<b>T-931</b>	76x76x22 mm - 3x3x0.80 inch	36 pz
<b>T-932</b>	100x100x22 mm - 4x4x0.80 inch	24 pz
<b>T-933</b>	152x152x22 mm - 6x6x0.80 inch	12 pz
<b>T-934</b>	305x305x22 mm - 12x12x0.80 inch	8 pz
<b>T-935</b>	460x460x22 mm - 18x18x0.80 inch	6 pz

[IT]

### TAPPETO ANTIVIBRANTE IN SBR

Tappeto antivibrante realizzato in gomma riciclata SBR, indicato per proteggere tetti con guaina.

[EN]

### ANTI-VIBRATION PAD MADE OF SBR

Anti-vibration pad made of recycled SBR rubber, ideal to protect the roof membrane.

[FR]

### TAPIS ANTI-VIBRATILES EN SBR

Tapis anti-vibratiles réalisés en caoutchouc recyclé SBR pour la protection des toits avec gaine.



					DENSITÀ DENSITY
<b>T-710</b>	tappeto piatto flat pad tapis plat	300 mm 12 inch	300 mm 12 inch	15 mm 0.59 inch	850 kg/m <sup>3</sup>
<b>T-700</b>		990 mm 39 inch	990 mm 39 inch	10 mm 0.39 inch	220 kg/m <sup>3</sup>
<b>T-709 [1]</b>	inclinato 3° sloped 3° incliné 3°	300 mm 12 inch	300 mm 12 inch	15/25 mm 0.59/0.98 inch	850 kg/m <sup>3</sup>
<b>T-708 [1]</b>	inclinato 5° sloped 5° incliné 5°	300 mm 12 inch	300 mm 12 inch	15/30 mm 0.59/1.18 inch	850 kg/m <sup>3</sup>

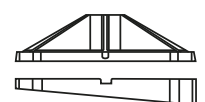

[1]

2 EME CLIMA



# DISTRIBUZIONE

## DISTRIBUTION



INQUADRA IL QR CODE E ACCEDI ALLA NOSTRA GAMMA DI DISTRIBUZIONE  
FRAME THE QR CODE AND HAVE A LOOK AT OUR DISTRIBUTION RANGE  
ENCADRE LE QR CODE ET ACCÈDE À NOTRE GAMME DE DISTRIBUTION



### ICONOGRAFIA / ICONOGRAPHY



**CODICE**  
CODE



**QUANTITÀ**  
QUANTITY / QUANTITÉ



**DIMENSIONI**  
DIMENSIONS



**PALLET**  
PALETTE



**PORTATA**  
LOAD CAPACITY / CHARGE



**DESCRIZIONE**  
DESCRIPTION



**COLORE**  
COLOUR / COULEUR



**MARKER**

20x15 mm  
41x21 mm

**PROFILI ALLUMINIO**  
ALUMINIUM STRUT  
PROFIL ALUMINIUM



**SUPPORTI POMPE DI CALORE**  
HEAT PUMPS SUPPORTS  
SUPPORTS POMPES À CHALEUR

## CONDIZIONI DI VENDITA

### VALIDE SOLO PER VENDITE IN ITALIA

#### ORDINI

Gli ordini di acquisto dovranno pervenire per iscritto e le richieste di variazione, aggiunte o annullamenti dovranno pervenire entro e non oltre le 48 ore dalla data d'invio dell'ordine stesso. Seguirà nostra conferma scritta riportante le condizioni pattuite. L'accettazione di un ordine prevede che l'importo fatturabile sia di almeno € 500,00 al netto di sconti, addebiti e IVA.

#### TERMINI DI CONSEGNA

La consegna verrà effettuata entro 10 giorni dal ricevimento dell'ordine. Possibili ritardi delle consegne non comportano responsabilità da parte del venditore.

#### IMBALLI

Adatti a garantire l'integrità degli articoli durante il loro trasporto.

#### TRASPORTO

Porto assegnato salvo accordi speciali. La merce viaggia sempre a rischio e pericolo del compratore anche se venduta franco destinatario.

#### PAGAMENTI

I pagamenti dovranno essere concordati tra le parti anticipatamente e saranno quelli indicati nella conferma d'ordine. In caso di ritardo nel pagamento, verrà bloccata immediatamente ogni fornitura e saranno applicati, dal giorno della mora, gli interessi legali.

#### RECLAMI

Eventuali reclami scritti saranno accettati entro 8 gg dalla data di ricevimento della merce. Eventuali resi della merce dovranno essere autorizzati per iscritto e saranno accettati solo se accompagnati da regolare d.d.t. e con imballo integro.

2 EMME CLIMA si riserva di variare le caratteristiche e i dati riportati nel presente catalogo in qualunque momento e senza preavviso. Tutti i dati qui riportati sono indicativi e non vincolanti.

[EN]

2 EMME CLIMA reserves the right to change the features and the information shown in the catalogue at any moment, without prior notice.  
The data indicated herein are purely indicative and not legally binding.

[FR]

2 EMME CLIMA se réserve le droit d'apporter des modifications aux caractéristiques mentionnées dans ce catalogue à tout moment et sans préavis.  
Les données sont indicatives et non juridiquement contraignantes.

IT  
EN  
FR

kfadiv.it



INQUADRA IL QR CODE E SCARICA L'APP  
2 EMME CLIMA AR  
FRAME THE QR CODE AND DOWNLOAD  
THE 2 EMME CLIMA AR APP  
ENCADRE LE QR CODE ET TÉLÉCHARGE  
L'APP 2 EMME CLIMA AR

**2 EMME CLIMA S.r.l. - A Socio Unico**

**Società sottoposta a direzione e coordinamento  
di Aspen Pumps Limited**

SEDE LEGALE: Via dell'Industria, 17  
35030 Bastia di Rovolon – Padova – Italy

SEDE OPERATIVA: Via dell'Industria, 28  
35030 Bastia di Rovolon – Padova – Italy

Italy - t. +39 049 9903985 - [INFO@2EMMECLIMA.COM](mailto:INFO@2EMMECLIMA.COM)

[www.2emmeclima.com](http://www.2emmeclima.com)

